

BreadCrumb® DX2

Ideal for lightweight autonomous vehicles

The DX2 is Rajant's smallest and lightest BreadCrumb, forming a mesh network when used in conjunction with other BreadCrumb systems. Encased in magnesium, it weighs 123g with a MIMO-antenna system and is designed for private wireless networks on lightweight autonomous vehicles. Its small footprint and very low payload weight make it ideal for drone swarms, remote CCTV, telematics monitoring, and most things mobile.



BreadCrumb DX2 Key Features

- Rajant's patented InstaMesh®¹ networking software, enabling the network to quickly adapt to rapidly-deployed and quickly- or constantly-moving network elements
- 2.4GHz or 5GHz radio frequencies supporting a wide variety of applications and environments
- One transceiver and two external antenna ports with low power consumption
- Pocket-size, lightweight, portable, and completely adaptive
- Ideal for lightweight autonomous vehicles, drones, and small robots
- Support for several strong cryptographic options used for data and MAC-address encryption and per-hop, per-packet authentication (list of options on page 3)
- High bandwidth for data, voice, and video applications
- Scalability to hundreds of mobile, high-bandwidth nodes
- Integrated Wi-Fi Access Point service for compatibility with millions of commercial off-the-shelf (COTS) client devices, such as laptops, tablets, smart phones, IP cameras, sensors, and other IP devices
- Self-configuring operation for fast and easy deployments
- Reliable and fast off-loading to Ethernet via multiple, simultaneous bridge-mode links through the Automatic Protocol Tunneling (APT) feature

The DX2 is designed to perform flawlessly in a variety of environments and are especially ideal for drone swarms.

Utilizing DX2 BreadCrumbs to Your Advantage

Crafted in 100% magnesium and weighing only 123g, the DX2 is Rajant's smallest and lightest BreadCrumb to date and is especially ideal for drones. It is our single-transceiver, MIMO-antenna system, frequently used in private wireless networks, and is fully compatible with the other BreadCrumbs in the Rajant product portfolio line. As a result, the DX2 can be combined with Rajant's LX5, ME4, and ES1 models to form a total mesh solution. Additionally, a hidden USB connector, to be used for GPS or TRoIP, lies behind a rear black rubber plug.

With its small lightweight size, the DX2 can be used an infinite number of locations in addition to lightweight autonomous vehicles. Its tiny mass also makes it a best choice for a communication node for swarms.

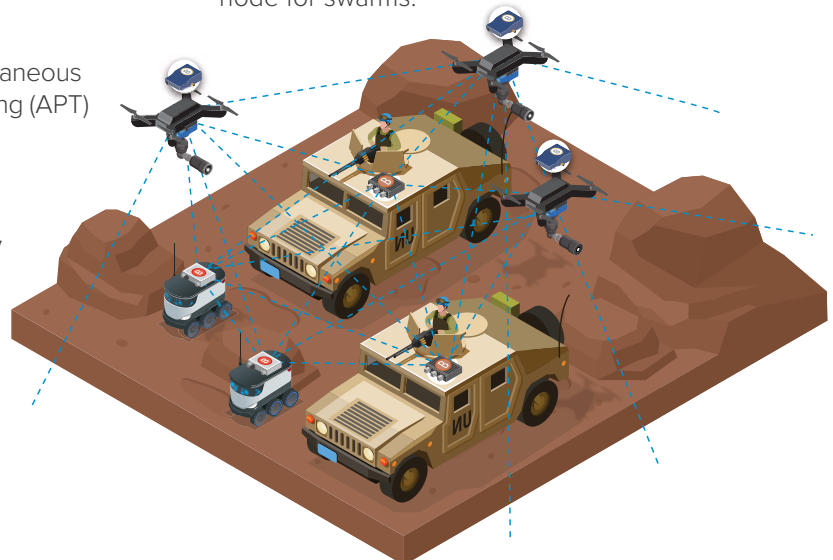

¹ U.S. Patent 8341289B2

InstaMesh®

InstaMesh is the advanced, patented¹ protocol developed by Rajant that directs the continuous and instantaneous forwarding of wireless and wired connections. It enables complete network mobility, robust fault tolerance, high throughput, and low latency with very low maintenance and administrative requirements. Because InstaMesh operates at Layer 2 and does not use a root node or LAN Controller, mobility and bandwidth are maximized. No matter how you configure your network, InstaMesh networking software always determines the most efficient pathway between any two points, even when those points are in motion.

This diagram shows how your Rajant mesh network can adapt to the changes caused by the movement of Node E. New links are established in real-time keeping the network available, intact and secure.

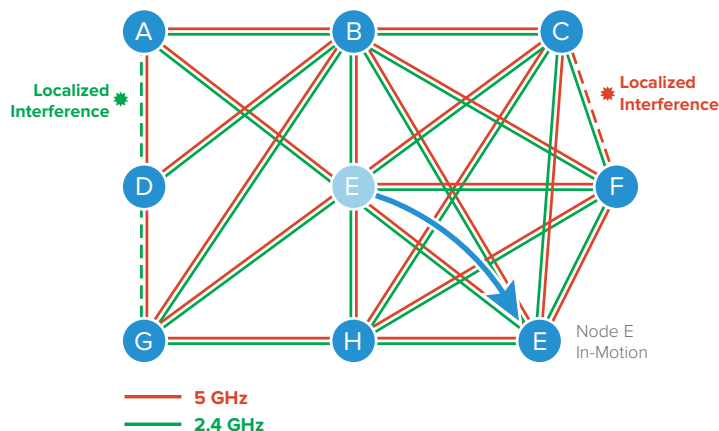

¹ U.S. Patent 8341289B2

Model	Description
DX2-24	DX2 with (1) 2.4 GHz, 2x2 MIMO, 300 Mbps transceiver.
DX2-50	DX2 with (1) 5.0 GHz, 2x2 MIMO, 300 Mbps transceiver.

Wireless	2.4 GHz	5 GHz
Antenna Connector	(2) SMA (female)	(2) SMA (female)
Frequency²	2402 – 2482 MHz	U-NII-1: 5150 – 5250 MHz U-NII-2A: 5250 – 5350 MHz U-NII-2C: 5470 – 5725 MHz U-NII-3: 5725 – 5850 MHz
Modulation	DSSS, CCK, OFDM	OFDM
Max. Physical Layer Data Rate	300 Mbps (throughput varies)	300 Mbps (throughput varies)
Max. RF Transmit Power³	30 dBm ± 1 dB	27 dBm ± 2 dB
Receive Sensitivity	-100 dBm (@ 1 Mbps, 20 MHz channel bandwidth) to -76 dBm (@ MCS7, 40 MHz channel bandwidth)	-96 dBm (@ 6 Mbps, 20 MHz channel bandwidth) to -76 dBm (@ MCS7, 40 MHz channel bandwidth)

² Channel, frequency and bandwidth options will vary based upon regional and local regulations and certifications.

³ RF transmit power is governed by local regulations and varies by frequency. For 2x2 MIMO capable transceivers, the Max. RF Transmit Power specification is for the combined power output of the two antenna ports.

Network & Security

Network Functionality

VLAN and QoS support; Access Point; Bridge; Gateway; DHCP; NAT and Port Forwarding; Automatic Protocol Tunneling (APT).

Security

- Multiple cryptographic options, including NSA Suite B algorithms (implementation not certified). For information on models with full Suite B certification, contact Rajant or your authorized Rajant partner.
- Separately configurable data and MAC address *encryption* via AES256-GCM, AES192-GCM, AES128-GCM, AES256-CTR, AES192-CTR, AES128-CTR, XSalsa20, XSalsa20/12, and XSalsa20/8.
- Configurable per-hop, per-packet *authentication* between BreadCrumbs via AES256-GMAC, AES192-GMAC, AES128-GMAC, HMAC-SHA512, HMAC-SHA384, HMAC-SHA256, HMAC-SHA224, HMAC-SHA1, and Poly-1305-AES.
- Supports IEEE 802.11i: AES-CCMP and TKIP encryption, WPA-Personal/Enterprise, WPA2-Personal/Enterprise, 802.1x; 64/128-bit WEP; Access Control Lists; Compatible with Layer-2 and Layer-3 client/server and peer-to-peer security solutions; Compatible with Harris SecNet 54® encryption.

Power

Input Voltage 8 — 60 VDC

Power Consumption⁴ 2.8 W (average, idle); 7.5 W (maximum, peak) @ 24 V

Input / Output

Ethernet (1) 10/100/1000 Mbps IEEE 802.3, RJ-45, auto MDI/MDIX

USB Micro-B USB port for firmware upgrades, and for GPS device add-on

LED Status LED

Physical

Dimensions 108 mm x 43 mm x 40 mm (4.252" x 1.693" x 1.575")

Weight 123 g ± 10 g (4.4 oz ± 0.4 oz)

Temperature Operating: -40° C to +60° C (-40° F to +140° F)
Storage: -40° C to +60° C (-40° F to +140° F)

Enclosure⁵ Magnesium, unsealed

Certifications FCC (US): DX2-24, DX2-50
IC (Canada): DX2-24, DX2-50
AS/NZS 4268 (Australia and New Zealand): DX2-24

Warranty 1 Year



⁴ Power consumption depends on transceiver configuration.

⁵ Exposure to water, particulates, excessive humidity, excessive shock and vibration, and/or temperature extremes or fluctuations may void the manufacturer's warranty.